

AS-120

→ Galvanised, Galvanised Ali Bronze, 316 Stainless Steel

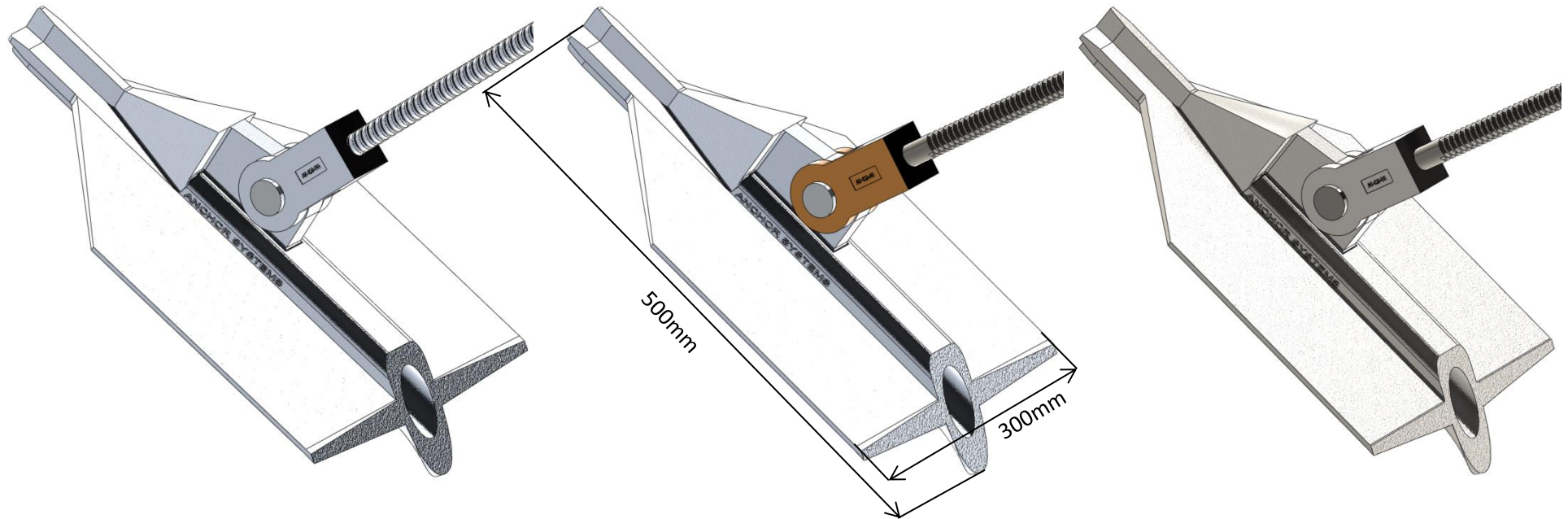

Anchor Systems (Europe) Ltd, Unit 45 Rowfant Business Centre, Rowfant, West Sussex, RH10 4NQ



Registered Office: North House 198 High Street, Tonbridge, Kent, TN9 1BE
Company Registration No. 04023935, VAT Registered No.656490607



Mechanical Anchoring Systems
DUCKBILL® ANCHORS • HELICAL ANCHORS
SOCK ANCHORS • ANCHOR POSTS

